

ESP12

POWERED ROLL LIFT TRANSPORT CART

FEATURES & BENEFITS

BATTERY OPERATED WITH BUILT-IN-CHARGER.

*CHARGER AUTOMATICALLY SHUTS OFF WHEN THE BATTERY IS FULLY CHARGED.

*USES STANDARD 120V OUTLET TO RECHARGE.

*NO BULKY EXTERNAL CHARGER UNIT NEEDED.

SAFEST METHOD OF MOVING ROLLS BY SUPPORTING THE ROLL FROM THE CORE, THE ESP12 IS STABLE AND EASY TO MANEUVER THUS REDUCING OPERATOR FATIGUE AND INCREASING SAFETY.

LIFT MECHANISM IS CONTROLLED BY TWO SWITCHES FOR SAFETY KEEPING THE OPERATORS HANDS AWAY FROM THE LIFT ARMS DURING OPERATION.

SWIVEL CASTERS - ALLOW THE ESP12 TO TURN ON ITS AXIS, INCREASING MANEUVERABILITY IN TIGHT QUARTERS.

FUNCTIONALITY - WHILE THE ESP12 WAS DESIGNED TO BE USED WITH THE ESP400 ROLL UNWIND AND THE ESP300 ROLL REWIND IT CAN ALSO BE USED AS A SAFE AND EFFECTIVE WAY TO MOVE ROLLS OF PAPER IN ANY PRINTING ENVIRONMENT.



SAFELY AND EASILY LOAD AND UNLOAD ROLLS

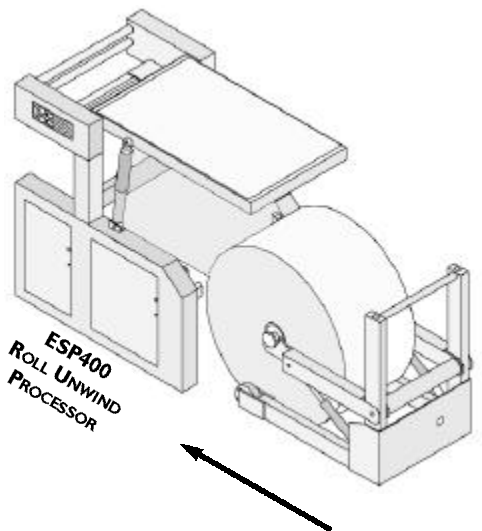

SPECIFICATIONS

MACHINE

HEIGHT	42"
WIDTH	28½"
LENGTH	42"
WEIGHT	260 LB.
ELECTRICAL (DURING CHARGE)	0.5 KVA 120V 50/60HZ*

ENVIRONMENTAL

TEMPERATURE	30° TO 110° F
HUMIDITY	20% TO 90%

FORMS

ROLL DIAMETER	MAX. 52"
ROLL WIDTH	MAX. 20"
ROLL WEIGHT	MAX. 1,200 LB.

OPTIONS

*INTERNATIONAL POWER OPTION



ESP, ENERGY SAVING PRODUCTS
713 GEORGE WASHINGTON TPKE
BURLINGTON, CT 06013-2037
860.675.6443

www.espcorp.com • 4sales@espcorp.com

NOTE: Specifications may change without notice. 10/01